

BGS12A

SPDT RF Switch

Small Signal Discretes



Never stop thinking

Edition 2007-09-14

**Published by
Infineon Technologies AG
81726 München, Germany**

**© Infineon Technologies AG 2007.
All Rights Reserved.**

Legal Disclaimer

The information given in this document shall in no event be regarded as a guarantee of conditions or characteristics ("Beschaffenhheitsgarantie"). With respect to any examples or hints given herein, any typical values stated herein and/or any information regarding the application of the device, Infineon Technologies hereby disclaims any and all warranties and liabilities of any kind, including without limitation warranties of non-infringement of intellectual property rights of any third party.

Information

For further information on technology, delivery terms and conditions and prices please contact your nearest Infineon Technologies Office (www.infineon.com).

Warnings

Due to technical requirements components may contain dangerous substances. For information on the types in question please contact your nearest Infineon Technologies Office.

Infineon Technologies Components may only be used in life-support devices or systems with the express written approval of Infineon Technologies, if a failure of such components can reasonably be expected to cause the failure of that life-support device or system, or to affect the safety or effectiveness of that device or system. Life support devices or systems are intended to be implanted in the human body, or to support and/or maintain and sustain and/or protect human life. If they fail, it is reasonable to assume that the health of the user or other persons may be endangered.



BGS12A

Revision History: 2007-09-14, V1.1

Previous Version: 2006-10-19, V1.0

Page	Subjects (major changes since last revision)
All	Document layout change

BGS12A

Features

- Low insertion loss
- High port-to-port-isolation
- Low harmonic generation
- On-chip control logic
- Lead free solder bumps
- High ESD robustness
- No external components required
- General purpose switch for applications up to 3 GHz
- Pb-free (RoHS compliant) package



Description

The BGS12A General Purpose RF MOS switch is designed to cover a broad range of applications from 0.1 to 3 GHz. The symmetric design of its single pole double throw configuration, as shown in [Figure 1](#) offers high design flexibility. This single supply chip integrates on-chip CMOS logic driven by a simple, single-pin CMOS or TTL compatible control input signal. The 0.1 dB compression point exceeds the switch's maximum input power level of 21 dBm, resulting in linear performance at all signal levels. The RF switch has a very low insertion loss of 0.3 dB in the 1 GHz and 0.6 dB in the 2 GHz range.

Unlike GaAs technology, external DC blocking capacitors at the RF ports are only required if DC voltage is applied externally.

The BGS12A RF switch is manufactured in Infineon's patented MOS technology, offering the performance of GaAs with the economy and integration of conventional CMOS including the inherent higher ESD robustness.

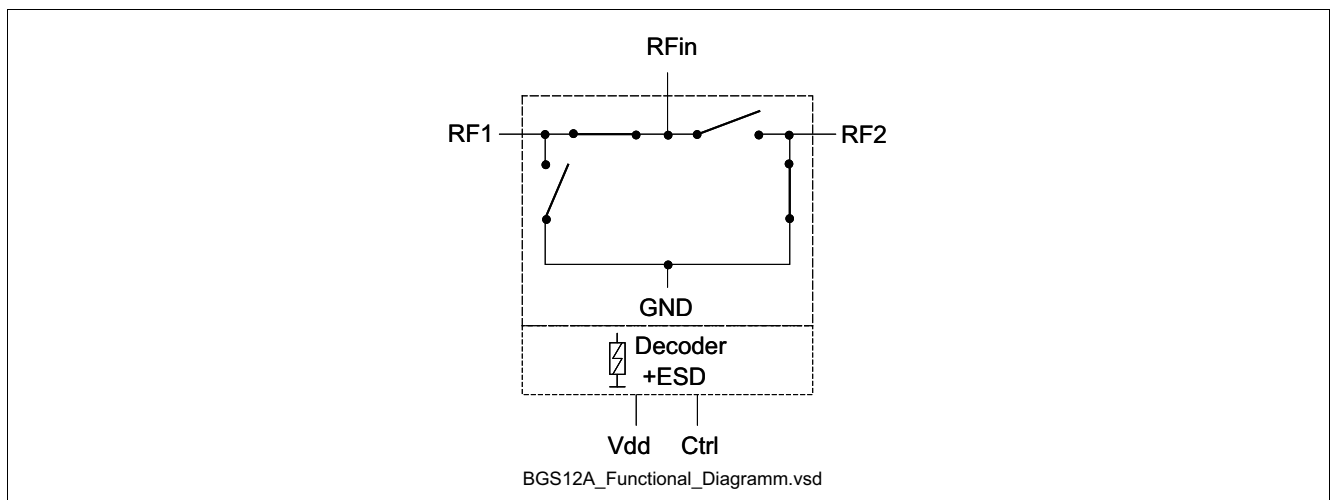

Figure 1 Functional Diagram

Type	Package	Marking	Chip
BGS12A	FWLP-6-1	12	N0735

Table 1 Maximum Ratings

Parameter	Symbol	Values			Unit	Note / Test Condition
		Min.	Typ.	Max.		
Storage temperature range	T_{stg}	-65		150	°C	
DC Voltage at all pins to GND	V_{DC}			5	V	
RF power max. at all RF ports	P_{IN}			24	dBm	
ESD Capability						
Human Body-Model IEC61340-3-1	V_{ESD}			1000	V	
Machine-Model IEC61340-3-2				100		

Table 2 Operation Ranges

Parameter	Symbol	Values			Unit	Note / Test Condition
		Min.	Typ.	Max.		
Ambient temperature	T_A	-30		85	°C	
RF Frequency	f	0.1		3	GHz	
Control voltage low	V_{CtrlL}	-0.3		0.3	V	
Control voltage high	V_{CtrlH}	1.4		2.8	V	
Supply voltage ¹⁾	V_{dd}	tbd		2.8	V	
Current consumption Vdd Pin (over temperature)	I_{Vdd}	80		350	μA	
Current Consumption Vctrl Pin	I_{Ctrl}			30	μA	
Power Range (VSWR ∞: 1) (VSWR 3: 1) (VSWR 1: 1)	P_{in}			15 18 21	dBm	

1) Supply voltage must be connected before Control Voltage

Table 3 Pin description

Pin	Name	Description
1	RF1	RF Port 1 Out
2	GND	Ground
3	RF2	RF Port 2 Out
4	CTRL	Control Pin
5	RFIN	RF Port In
6	Vdd	Supply Voltage

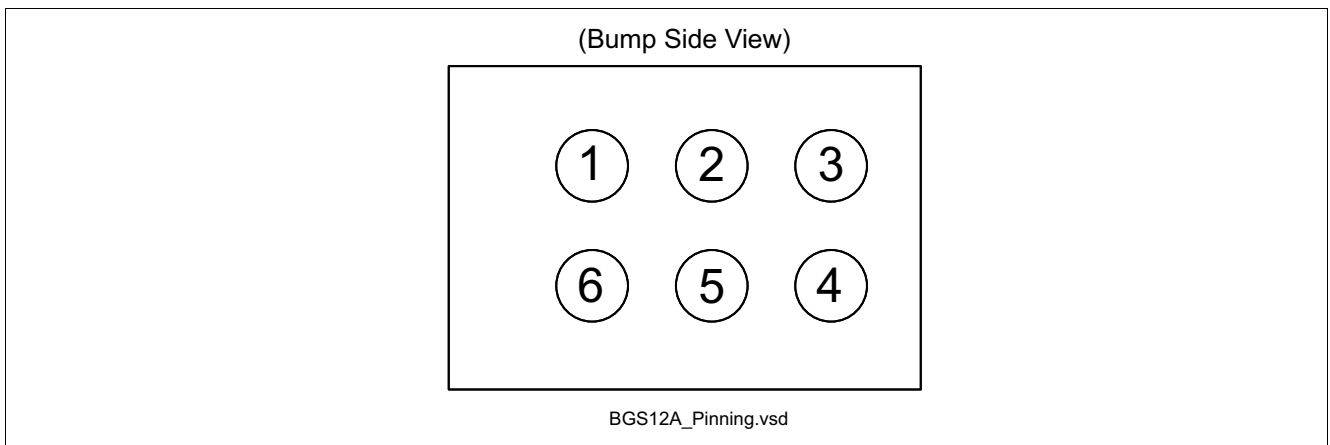

Figure 2 Pinning

Table 4 Truth Table

Ctrl 1	RF 1	RF 2
0	1	0
1	0	1

Electrical Specifications

- Termination port impedance: $Z_0 = 50 \Omega$
- Temperature range: $T = 25 \text{ }^\circ\text{C}$
- Supply Voltage: $V_{dd} = 2.8 \text{ V}$
- $P_{in} = 15 \text{ dBm}$
- Across operating range of control voltages: $V_{Ctrl} = 1.4 \dots 2.8 \text{ V}$

Table 5 Electrical Characteristics

Parameter	Symbol	Values			Unit	Note / Test Condition
		Min.	Typ.	Max.		
Insertion Loss ¹⁾	IL		0.3		dB	$f = 1 \text{ GHz TX}$
			0.6		dB	$f = 2 \text{ GHz TX}$
			0.4		dB	$f = 1 \text{ GHz TX},$ $T_A = 85 \text{ }^\circ\text{C}$
			0.8		dB	$f = 2 \text{ GHz TX},$ $T_A = 85 \text{ }^\circ\text{C}$
Return Loss	RL	15			dB	$f = 1 \text{ GHz}$
		10			dB	$f = 2 \text{ GHz}$
Isolation RFin - RF1	$ISO_{RFin-RF1}$	30	34		dB	$f = 1 \text{ GHz}$
		22	27		dB	$f = 2 \text{ GHz}$
Isolation RFin - RF2	$ISO_{RFin-RF2}$	30	34		dB	$f = 1 \text{ GHz}$
		22	27		dB	$f = 2 \text{ GHz}$
Isolation RF1 - RF2	$ISO_{RF1-RF2}$	30	43		dB	$f = 1 \text{ GHz}$
		28	34		dB	$f = 2 \text{ GHz}$
Isolation RF ports - Vdd, Vctrl	ISO_{RF-DC}	30	35		dB	$f = 1 \text{ GHz}$
		20	35		dB	$f = 2 \text{ GHz}$
Harmonic Generation up to 12.75 GHz	P_{Harm}		-75	-50	dBm	$f = 1 \text{ GHz}$
			-80	-50	dBm	$f = 2 \text{ GHz}$
On Switching Time (10-90%) RF	t_{on}			4	μs	$f = 1 \text{ GHz}$
Off Switching Time (10-90%) RF	t_{off}			4	μs	$f = 1 \text{ GHz}$
Current Consumption at Vdd Pin	I_{dd}		120		μA	
Input 0.1 dB compression	$P_{0.1dB}$	21			dBm	$f = 1 \text{ GHz}$

1) With external matching at antenna port

Package Outlines

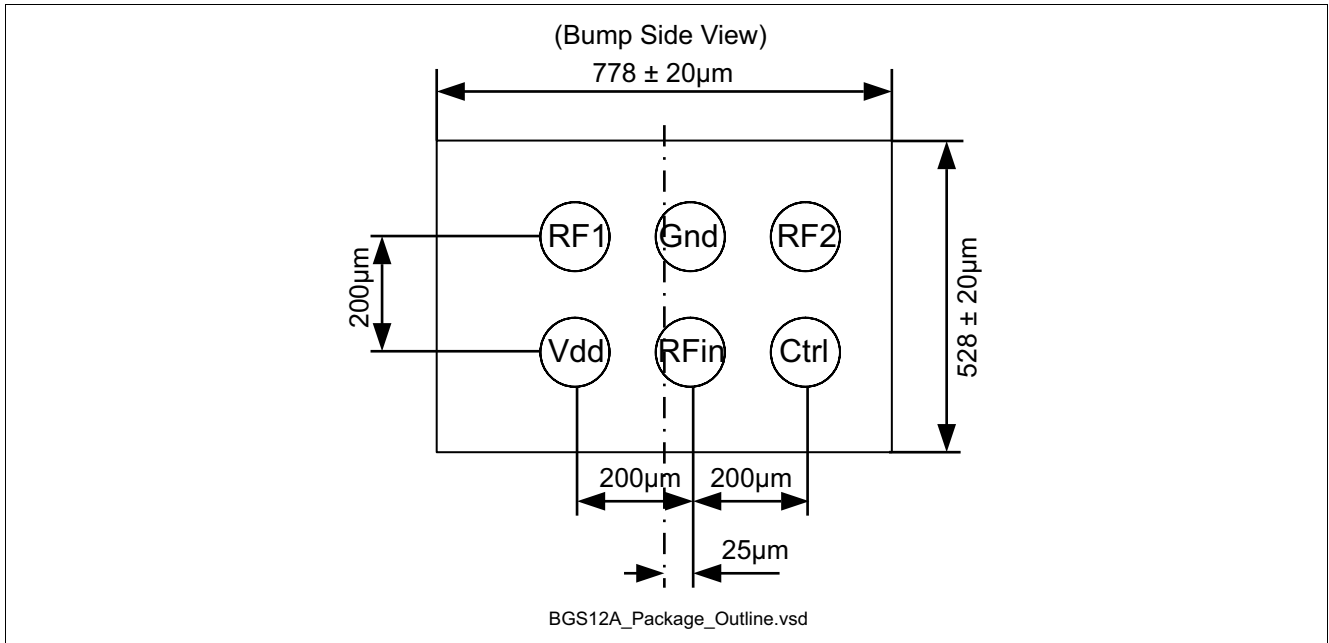

Figure 3 Package outline

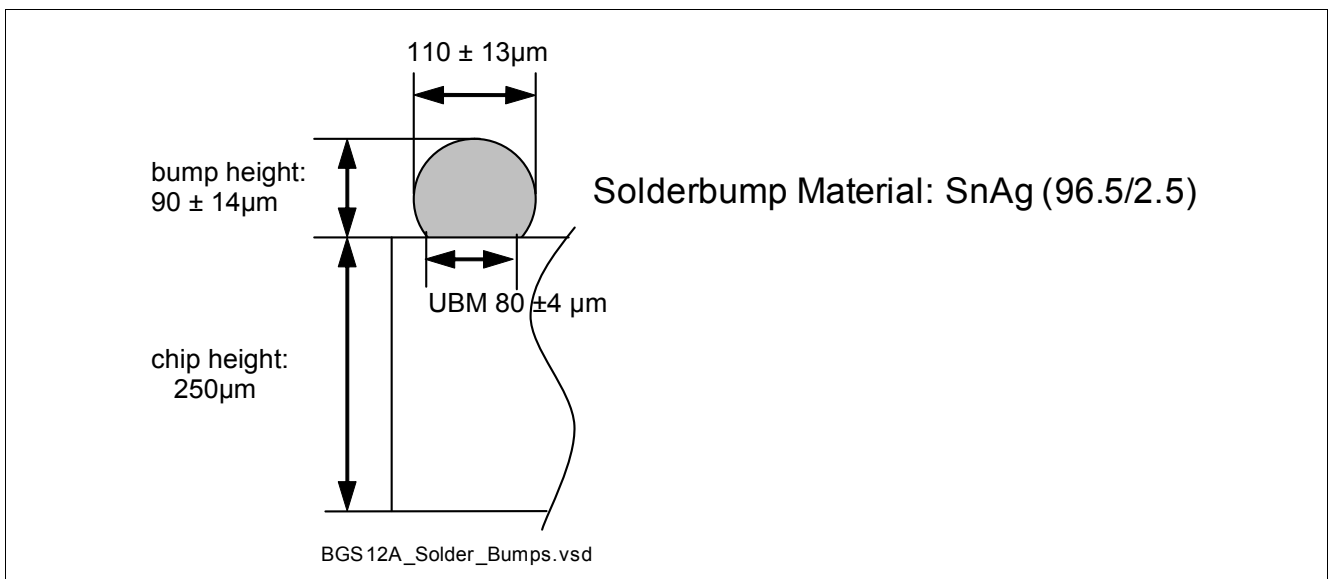

Figure 4 Solder bumps

Dimensions in mm

You can find all of our packages, sorts of packing and others in our Infineon Internet Page "Products":
<http://www.infineon.com/products>.